

Work happily



V1.2

naggura'swop

naggura.com

Onze producten



De Swop S3 HT SPA is een 3-delige massage en wellness tafel met 3 motoren, een matras uit één stuk, houten bekleding, TwinLift armsteunen en bladverwarming.

Hout, Metaal of Pmma



Collectie paneeltjes

Nordic
METAAL

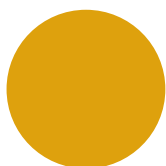

Yellow

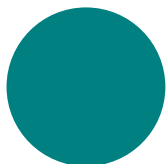

Blue

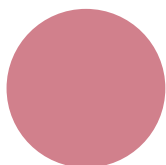

Pink

Foll
METAAL



Ash

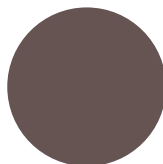

Clay

Iron
METAAL

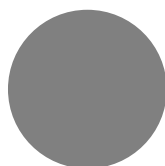

Inox

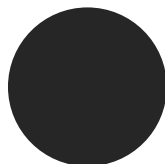

Black

Om
HOUT



Oak



Wenge

Techno
PMMA



Fluor

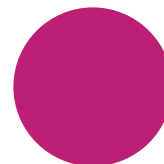

Fuxia



Ice

SWOP S3 HT SPA



Afmetingen en instelmogelijkheden

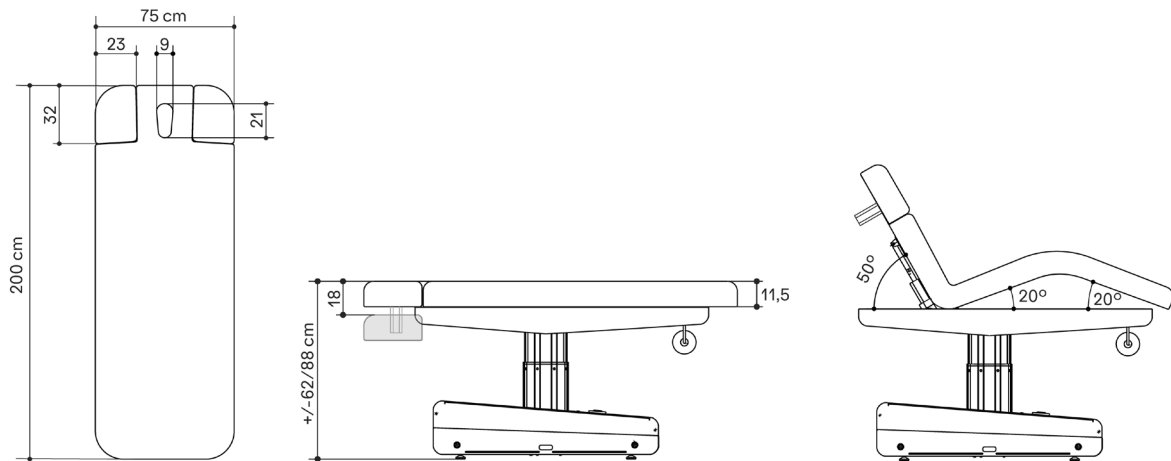

Algemene Specificaties

MOTOREN

3 motoren (hoogte, beendeel, rugleuning)

AFMETINGEN (LENGTE-BREEDTE)

200 x 75 cm

HOOGTE (MIN. AND MAX.)

62/88 cm

GEWICHT

110 kg

DIKTE KUSSENS

11,5 cm (10 cm latex en 1,5 cm houten voet)

POLSTERING

30 kg/m³ (zeer zacht)

MAXIMALE DYNAMISCHE BELASTING

175 kg

BEDIENING

Handschakelaar (inbegrepen)/ Voetschakelaar (optioneel)

STROOMVOORZIENING

230 V - 50/60 Hz

MAX. STROOMOPNAME

2 A

ELEKTRISCHE MOTOR HOOG/LAAG

6.000 N

STANDAARD TOEBEHOREN

Setje houten paneeltjes:
OAK
Papierrolhouder
TwinLift armsteunen
Bladverwarming

BEKLEDING

Kussens uit één geheel, perfect te reinigen.

Naggura Skin bekleding: 100% vinyl samenstelling in wit.

Een slijtvastheid van het kunstleer is maar liefst 250K en beschermt tegen bacteriën en UV stralen.

Unsere Produkte



Swop S3 HT SPA ist eine dreiteilige elektrische Liege mit einer einteiligen Matratze, Verkleidung aus Holz, TwinLift Armstützen und Polsterheizung.

Holz, Metall oder PMMA



Kollektionen

Nordic
METALL

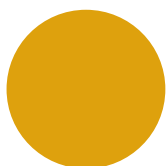

Yellow

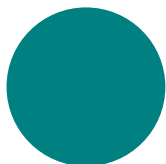

Blue

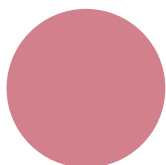

Pink

Foll
METALL



Ash

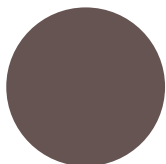

Clay

Iron
METALL

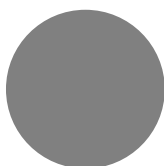

Inox

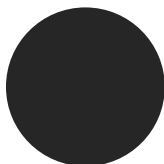

Black

Om
HOLZ



Oak



Wenge

Techno
PMMA



Fluor

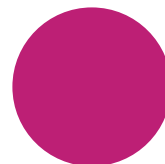

Fuxia



Ice

SWOP S3 HT SPA



Abmessungen

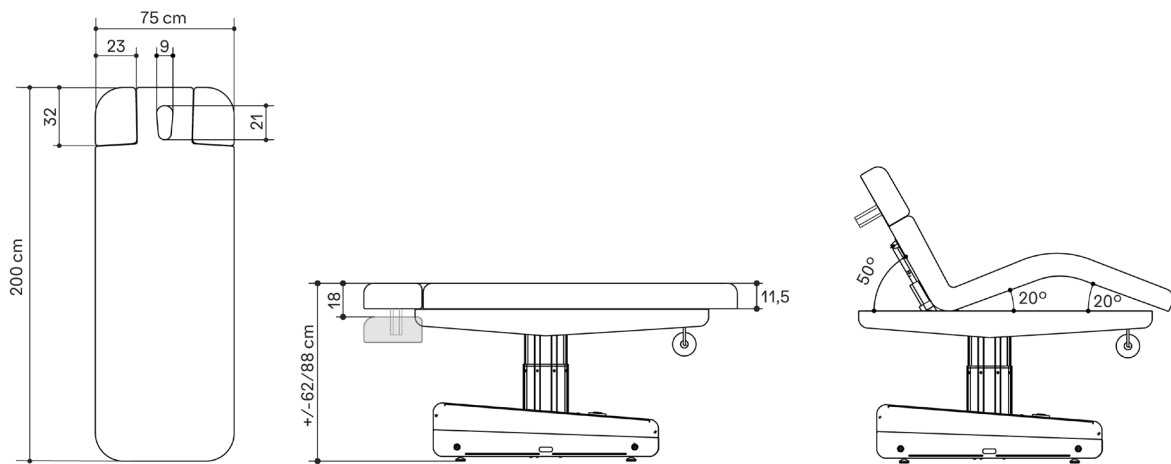

Technische Angaben

MOTOREN

3 Motoren (Höhe, Rückenlehne und Beinteil)

ABMESSUNGEN (LÄNGE X BREITE)

200 x 75 cm

HÖHE (MIN. UND MAX.)

62/88 cm

GEWICHT

110 kg

POLSTERDICKE

11,5 cm (10 cm Latex und 1,5 cm Sperrholz)

DICHTE

30 kg/m³

BELASTBARKEIT

175 kg

BEDIENUNG

Handfernbedienung (serienmäßige Ausstattung)/
Fußfernbedienung (optional)

STROMVERSORGUNG

230 V - 50/60 Hz

MAX. INTENSITÄT

2 A

ELEKTRISCHER MOTOR

6.000 N

ANGABEN

TwinLift Armstützen
Polsterheizung
Papierrollenhalter

POLSTERUNG

Nahtloser Polsterbezug und mit abgerundeten Kanten.

Naggura Skin Polsterbezug: 100 % Vinyl-Mischung in Weiß.

Abriebfestigkeit: >250.000 Zyklen. Schutz vor Keimen und UV-Strahlen.

Nos produits



La table Swop S3 HT SPA est une table électrique à 3 sections avec matelas monobloc, structure en métal et bois, système d'accoudoirs TwinLift et chauffage.

Bois, Métal ou PMMA



Collections

Nordic
MÉTAL

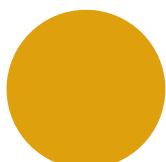

Yellow

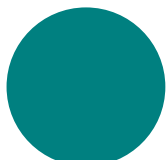

Blue

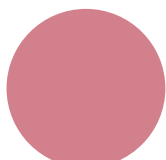

Pink

Foll
MÉTAL

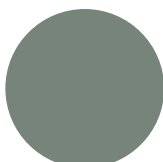

Ash

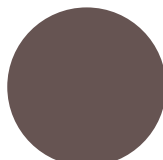

Clay

Iron
MÉTAL

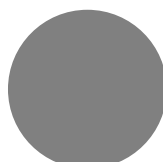

Inox

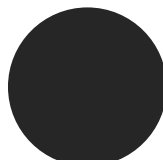

Black

Om
BOIS



Oak



Wenge

Techno
PMMA



Fluor

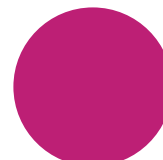

Fuxia



Ice



Dimensions

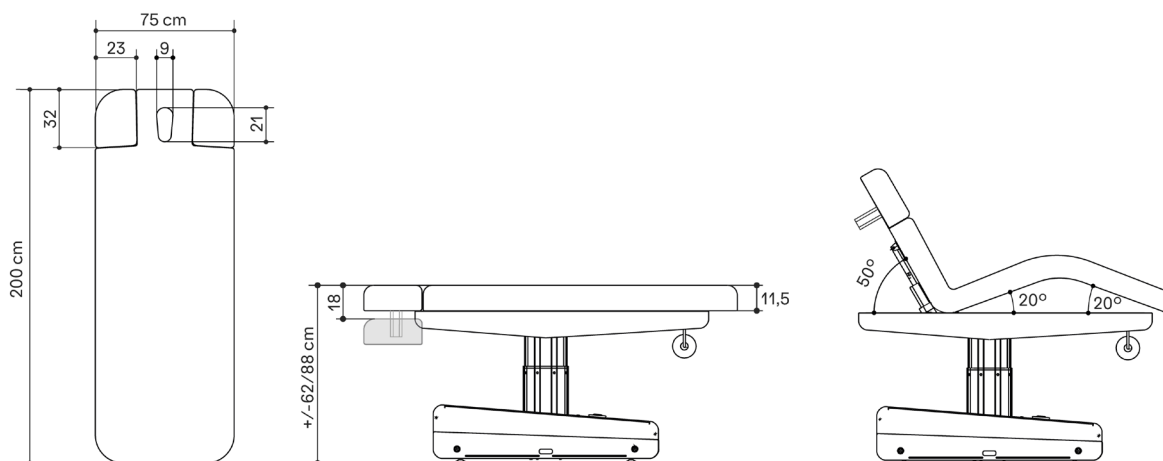

Spécifications générales

MOTEURS

3 moteurs (hauteur, repose-pieds, dossier)

DIMENSIONS (LONGUEUR X LARGEUR)

200 x 75 cm

HAUTEUR (MIN. ET MAX.)

62/88 cm

POIDS

110 kg

ÉPAISSEUR

11,5 cm (10 cm latex et 1,5 cm planche en bois)

DENSITÉ
30 kg/m³

CAPACITÉ DE CHARGE

175 kg

FONCTIONNEMENT

Télécommande à main (comprise)/Commande à pied (option)

ALIMENTATION

230 V - 50/60 Hz

INTENSITÉ MAX.

2 A

VÉRIN ÉLECTRIQUE

6.000 N

SPÉCIFICATIONS

Système d'accoudoirs
TwinLift
Chauffage
Porte-rouleau

MATELAS

Revêtement sans coutures et bords arrondis.

Revêtement avec Naggura Skin : 100% composé de vinyle en blanc.

Résistance à l'abrasion : >250.000 cycles. Protection contre germes et rayons UV.

I nostri prodotti



Swop S3 HT SPA è un lettino elettrico a 3 sezioni con materasso tutto d'un pezzo, rivestimento in legno, braccioli regolabili TwinLift e riscaldamento.

Legno, metallo o PMMA



Collezioni dei pannelli

Nordic
METALLO

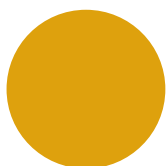

Yellow

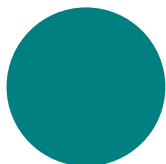

Blue

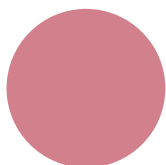

Pink

Foll
METALLO



Ash

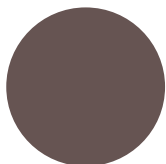

Clay

Iron
METALLO

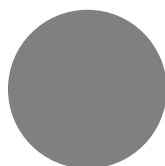

Inox

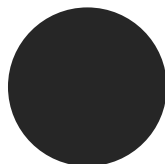

Black

Om
LEGNO



Oak



Wenge

Techno
PMMA



Fluor

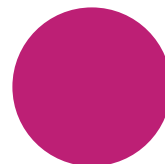

Fuxia



Ice

SWOP S3 HT SPA



Dimensioni

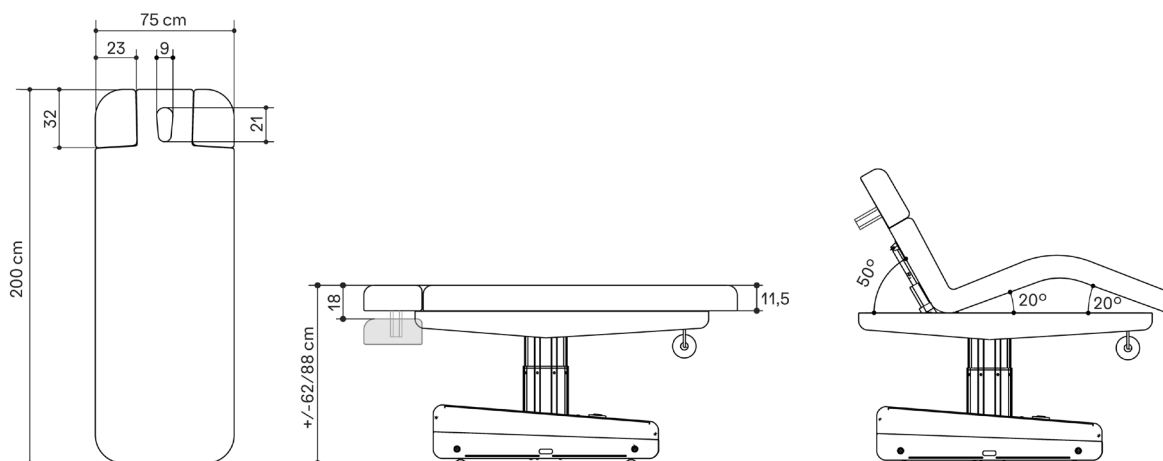

Caratteristiche tecniche

MOTORI

3 motori (altezza, inclinazione schienale e poggiatesta)

DIMENSIONI (LUNGHEZZA X LARGHEZZA)

200 x 75 cm

ALTEZZA (MINIMA E MASSIMA)

62/88 cm

PESO

110 kg

SPESORE

11,5 cm (10 cm lattice e 1,5 cm base in legno)

DENSITÀ
30 kg/m³

CAPACITÀ DI CARICO

175 kg

FUNZIONAMENTO

Telecomando (incluso)/
Pedaliera (opzionale)

ALIMENTAZIONE ELETTRICA

230 V - 50/60 Hz

POTENZA MASSIMA

2 A

MOTORE ELETTRICO

6.000 N

CARATTERISTICHE

Sistema di braccioli regolabili TwinLift
Riscaldamento
Portarotoli

RIVESTIMENTO

Rivestimento senza cuciture con bordi arrotondati.

Rivestimento Naggura Skin: 100% Mix vinilico in bianco.

Resistenza all'abrasione: >250.000 cicli. Protezione contro germi e raggi UV

Nuestros productos



Swop S3 HT SPA es una camilla eléctrica de 3 secciones con colchón continuo, revestimiento de madera, sistema apoyabrazos TwinLift y calefacción.

Madera, metal o PMMA



Colecciones

Nordic
METAL

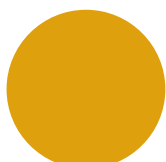

Yellow

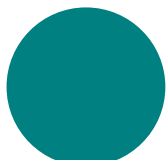

Blue

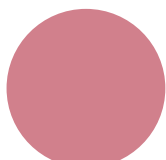

Pink

Foll
METAL



Ash

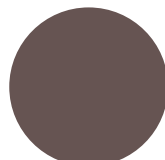

Clay

Iron
METAL

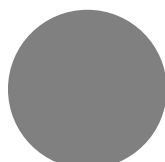

Inox

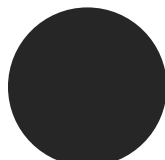

Black

Om
MADERA



Oak



Wenge

Techno
PMMA



Fluor

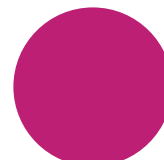

Fuxia



Ice

SWOP S3 HT SPA



Dimensiones

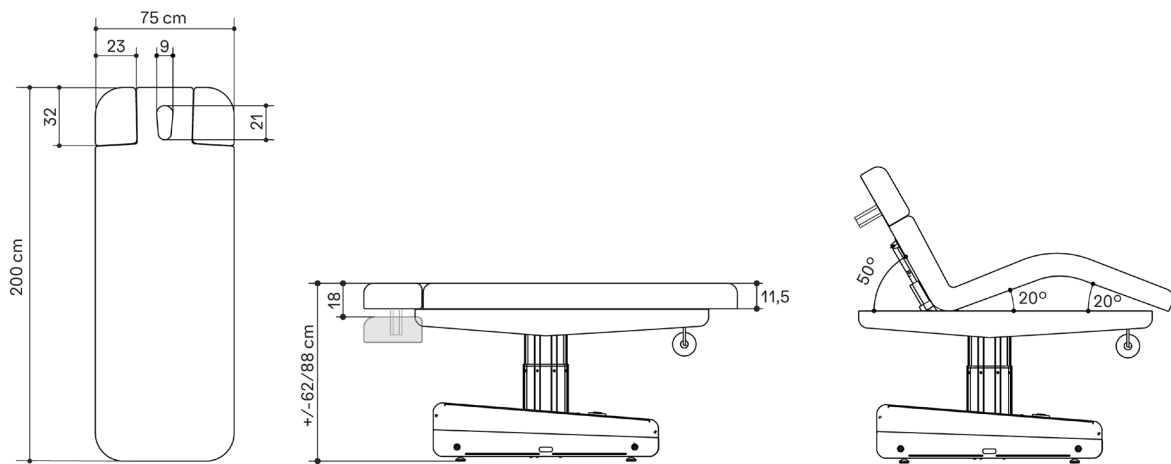

Características técnicas

MOTORES

3 motores (altura, inclinación respaldo y reposapiés)

DIMENSIONES (LARGO X ANCHO)

200 x 75 cm

ALTURA (MÍNIMA Y MÁXIMA)

62/88 cm

PESO

110 kg

ESPESOR

11,5 cm (10 cm viscoelástica y 1,5 cm base de madera)

DENSIDAD

30 kg/m³

CAPACIDAD DE CARGA

175 kg

FUNCIONAMIENTO

Mando (incluido)/ Pedal (opcional)

FUENTE DE ALIMENTACIÓN

230 V - 50/60 Hz

POTENCIA MÁXIMA

2 A

MOTOR ELÉCTRICO

6.000 N

CARACTERÍSTICAS

Sistema apoyabrazos
TwinLift
Calefacción
Portarrollos

TAPIZADO

Tapizado sin costuras y con bordes redondeados.

Tapizado con Naggura Skin: 100% Mezcla de vinilo en blanco.

Resistencia a la abrasión: >250.000 ciclos. Protección contra gérmenes y rayos UV.

Our products



Spa



The Swop S3 HT SPA is an electrical 3-section table with a one-piece mattress, wooden structure, TwinLift armrest system and heating.

Wood, Metal or Pmma



Collections

Nordic
METAL

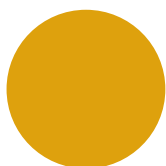

Yellow

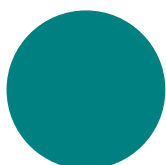

Blue

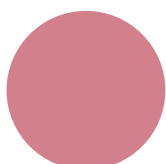

Pink

Foll
METAL



Ash

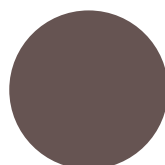

Clay

Iron
METAL

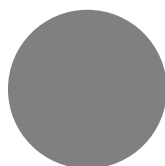

Inox

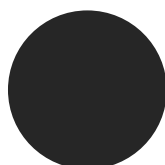

Black

Om
WOOD



Oak



Wenge

Techno
PMMA



Fluor

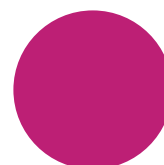

Fuxia



Ice

SWOP S3 HT SPA



Dimensions

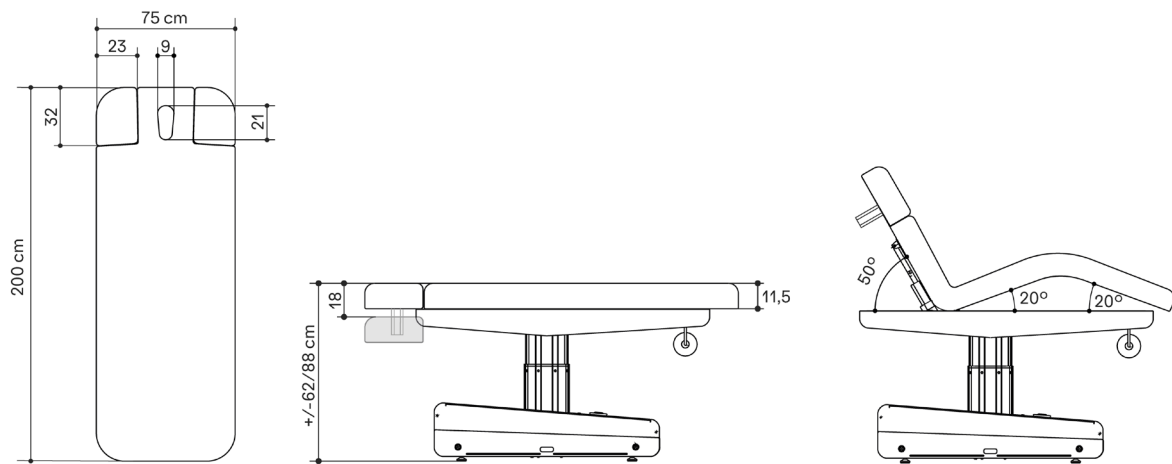

General specifications

MOTORS

3 engine (height, footrest, backrest)

DIMENSIONS (LENGTH X WIDTH)

200 x 75 cm

HEIGHT (MIN. AND MAX.)

62/88 cm

WEIGHT

110 kg

THICKNESS

11,5 cm (10 cm latex and 1,5 cm wood base)

DENSITY
30 kg/m³

LIFTING CAPACITY

175 kg

OPERATION

Hand controller (included)/
Foot controller (optional)

POWER SUPPLY

230 V - 50/60 Hz

MAX. INTENSITY

2 A

ELECTRIC MOTOR

6.000 N

FEATURES

TwinLift armrest system
Heating
Roll holder

CUSHION

Upholstery Seamless
round edges

Naggura Skin upholstery:
100% vinyl compound in
white.

Superior abrasion resis-
tance: >250.000 cycles.
Protection against germs
and UV rays.